

FINITE ELEMENT ANALYSIS OF THE CLASSIC BICYCLE FRAME

DILEEP PANCHAL , L. SUNIL*

* Department of Mechanical Engineering, St.Martin's Engineering college Dullapally ,Secunderabad

Emai Id: Dileep.panchal05@gmail.com

ABSTRACT

Analysis of Bicycle Frame by using 3D CAD MODELLING TOOL. In this project we are going to design Bicycle Frame by using 3D CAD Modelling tool i.e., CATIA V5 R20. After completion of design we are

going to do structural analysis on frame with the use of existing material and proposed material and we'll conclude why the proposed material is better than the existing material.

Keywords: *bicycle, modelling and Frame.*

1. INTRODUCTION

A **bicycle frame** is the main component of a bicycle, onto which wheels and other components are fitted. The modern and most common frame design for an upright bicycle is based on the safety bicycle, and consists of two triangles: a main triangle and a paired rear triangle. This is known as the *diamond frame*. Frames are required to be strong, stiff and light, which they do by combining different materials and shapes.

A **frameset** consists of the frame and fork of a bicycle and sometimes includes the headset and seat post. Frame builders will often produce the frame and fork together as a paired set.

The length of the tubes, and the angles at which they are attached define a **frame geometry**. In comparing different frame geometries, designers often compare the seat tube angle, head tube angle, (virtual) top tube length, and seat tube length. To complete the specification of a bicycle for use, the rider adjusts the relative positions of the saddle, pedals and handlebars:

2.2 Frame size

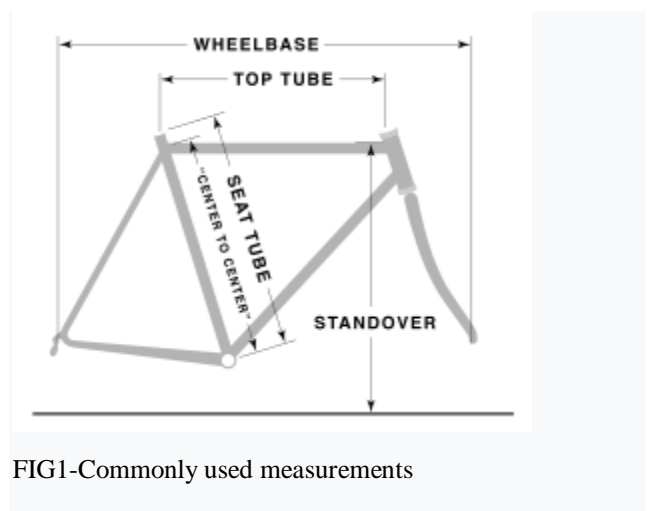

FIG1-Commonly used measurements

Frame size was traditionally measured along the seat tube from the center of the bottom bracket to the center of the top tube. Typical "medium" sizes are 54 or 56 cm (approximately 21.2 or 22 inches) for a European men's racing bicycle or 46 cm (about 18.5 inches) for a men's mountain bike. The wider range of frame geometries that now exist has also led to other methods of measuring frame size. Touring frames tend to be longer, while racing frames are more compact.

2.3 Frame materials

Historically, the most common material for the tubes of a bicycle frame has been steel. Frames can be made of varying grades of steel, from very inexpensive carbon steel to more costly and higher quality chromium molybdenum steel alloys. Frames can also be made from aluminum alloys, titanium, carbon fiber, and even bamboo and cardboard. Occasionally, diamond (shaped) frames have been formed from sections other than tubes. These include I-beams and monocoque.

Materials that have been used in these frames include wood (solid or laminate), magnesium (cast I-beams), and thermoplastic.

In this paper we are used these material for making bicycle frame in catia modelling software those are Steel alloy, alloy steel super alloy A286 and Ti-12M0-6Zr-2Fe-Titanium alloy

MODELING OF cycle frame

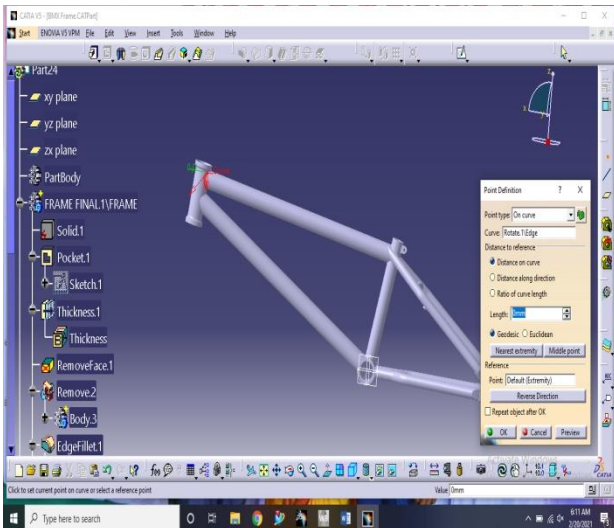

FIG2-Point1

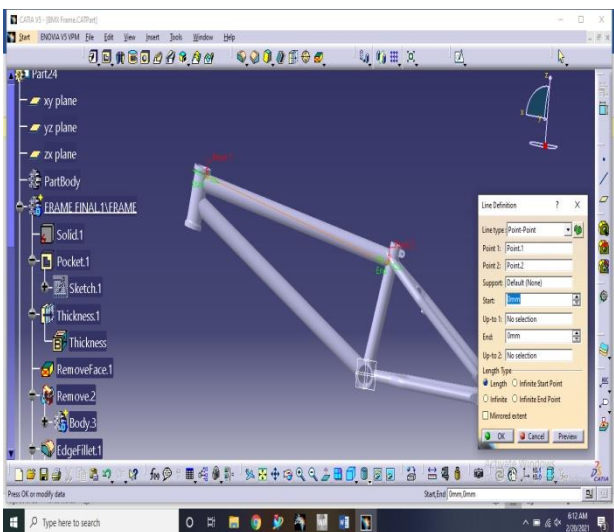

FIG3-Line 1

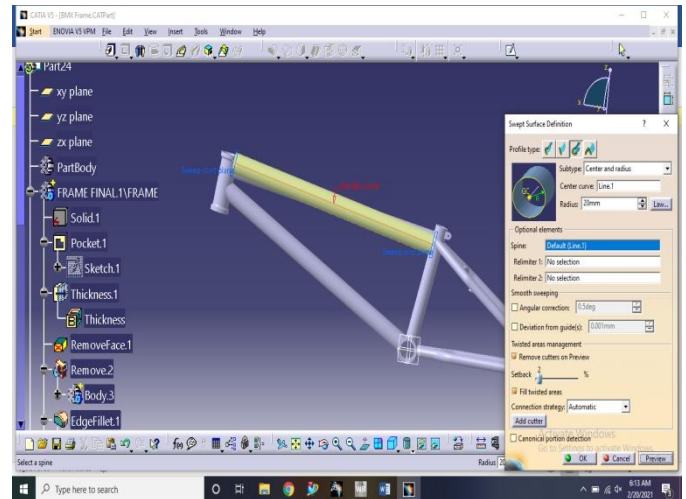

FIG4-Sweep 1

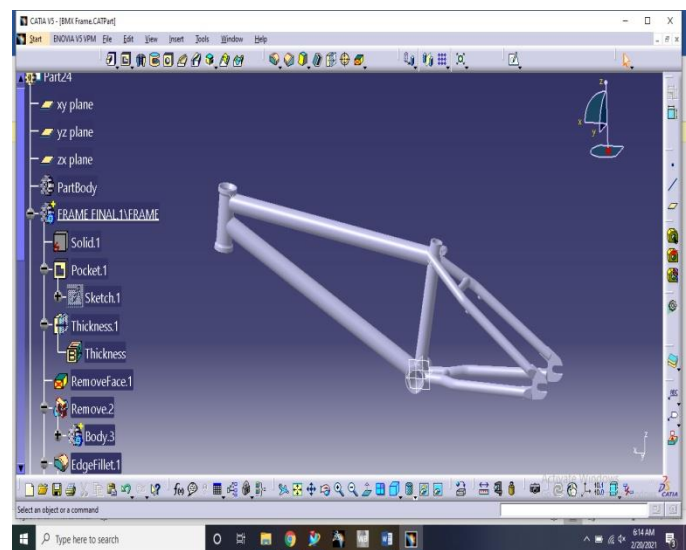

FIG5-Final design

ANALYSIS

I. ANALYSIS STEPS:

The steps needed to perform an analysis depend on the study type. You complete a study by performing the following steps:

- Create a study defining its analysis type and options.
- If needed, define parameters of your study. A parameter can be a model dimension, material property, force value, or any other input.
- Define material properties.
- Specify restraints and loads.

- The program automatically creates a mixed mesh when different geometries (solid, shell, structural members etc.) exist in the model.
- Define component contact and contact sets.
- Mesh the model to divide the model into many small pieces called elements. Fatigue and optimization studies use the meshes in referenced studies.
- Run the study.
- View results.

In this section, the modeling and analysis of the thermoelastic problem will be described. Start the **ANSYS Product Launcher**. Select a working directory for storing your model data and launch **ANSYS Workbench**. You will see the software outfit.

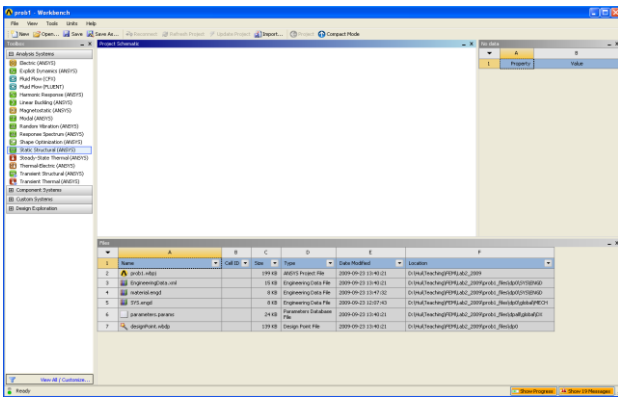

Fig10-ENGINEERING DATA

Drag **Static Structural (ANSYS)** tab from **Analysis Systems** of **Toolbox** window to the **Project Schematic** window. Now, your static structural analysis model should be in the **Project Schematic**.

PROJECT ANALYSIS

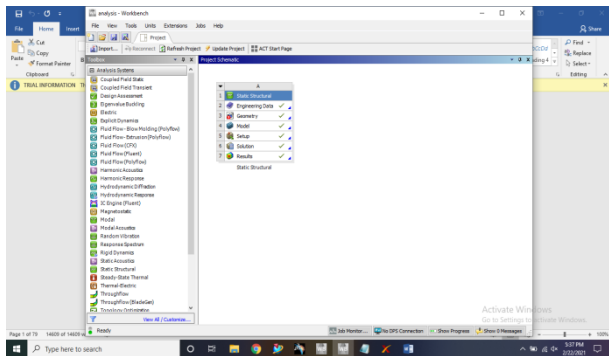

Fig10-ENGINEERING DATA

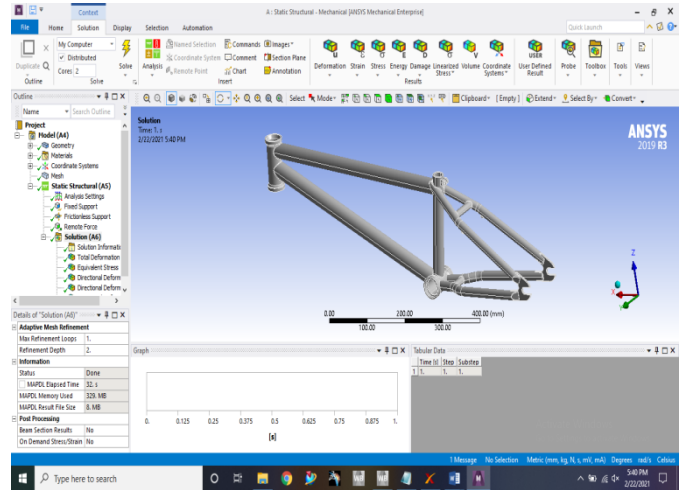

FIG11-GEOMETRY

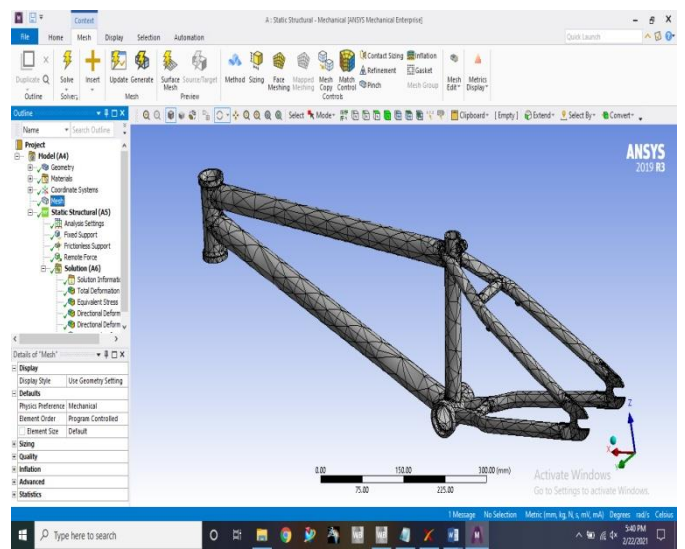

FIG12-MESH

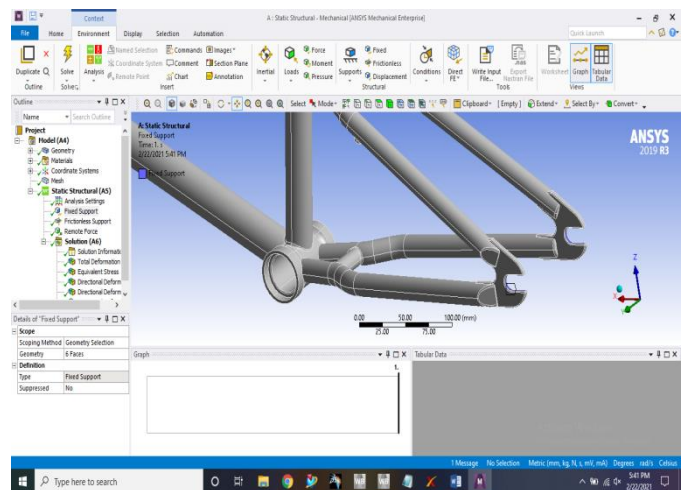

FIG13-FIXED SUPPORT

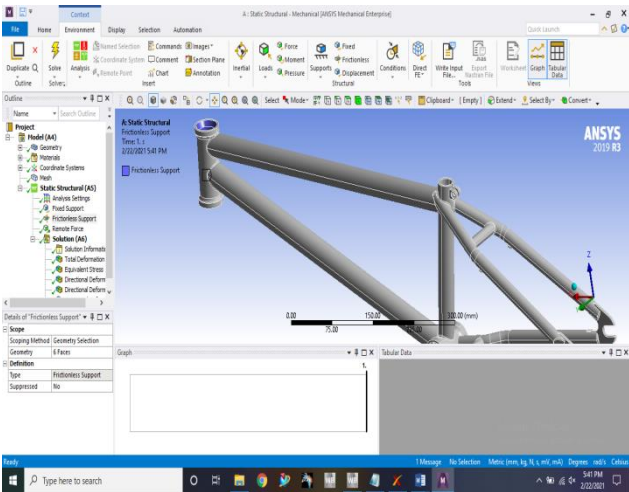

FIG14-FRICTIONLESS SUPPORT

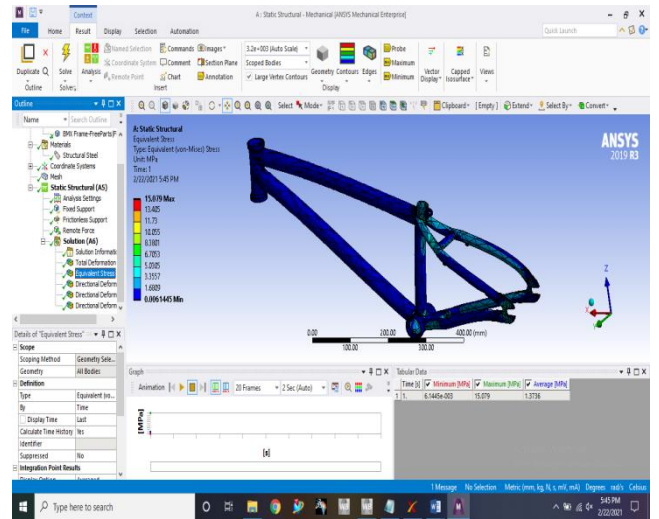

FIG17-STRESS

ALLOY STEEL SUPER ALLOY A286

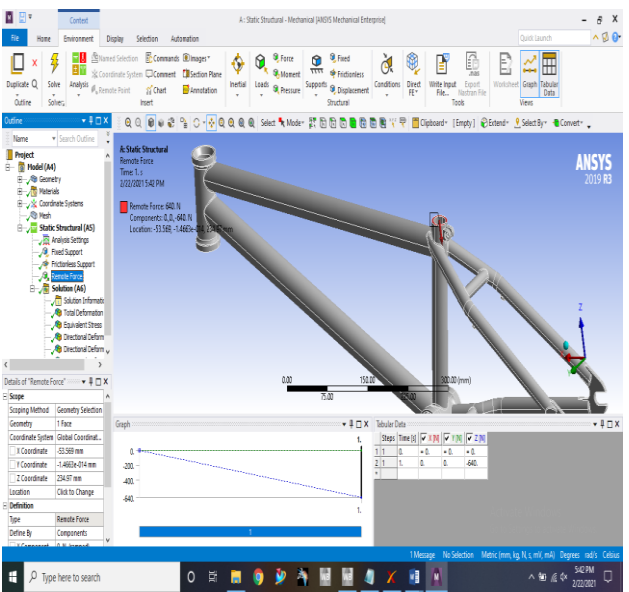

FIG15-REMOTE FORCE

RESULT AND COMPARISON

STEEL ALLOY

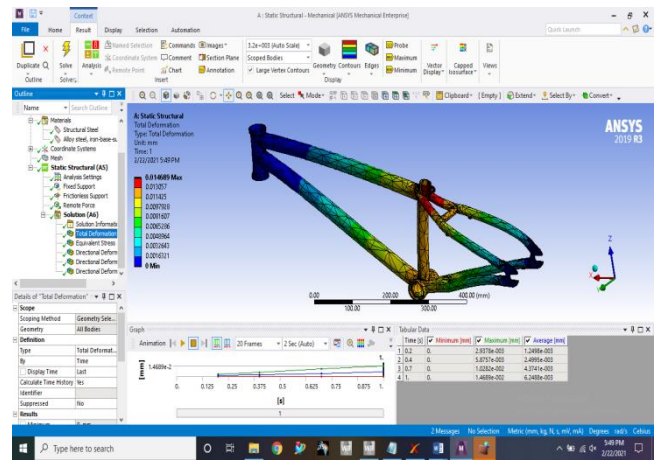

FIG18-TOTAL DEFORMATION

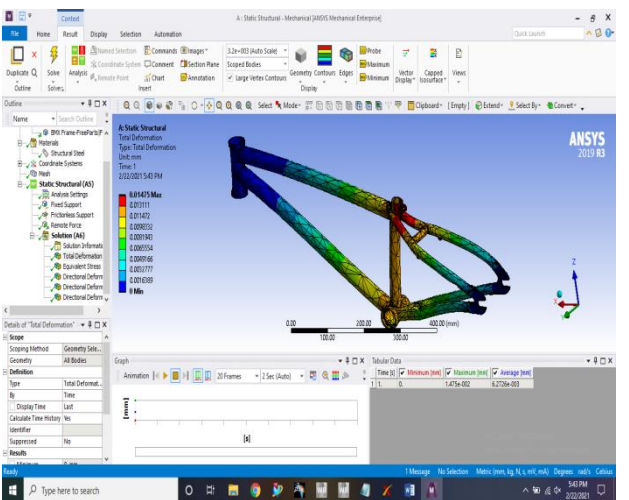

FIG16-TOTAL DEFORMATION

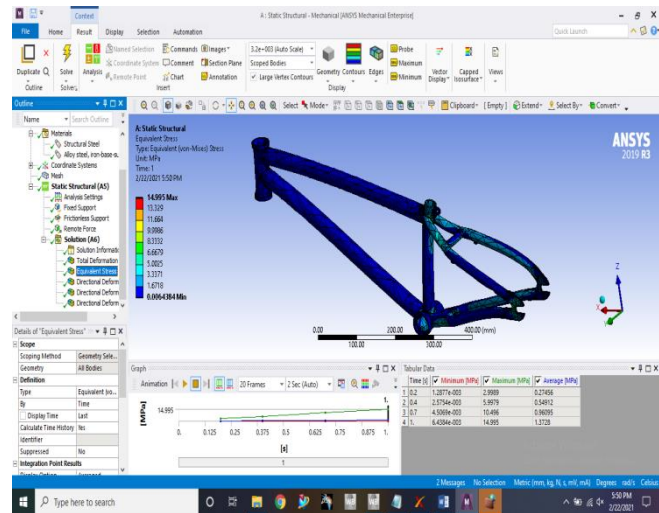

FIG19-STRESS

Ti-12Mo-6Zr-2Fe-titanium alloy

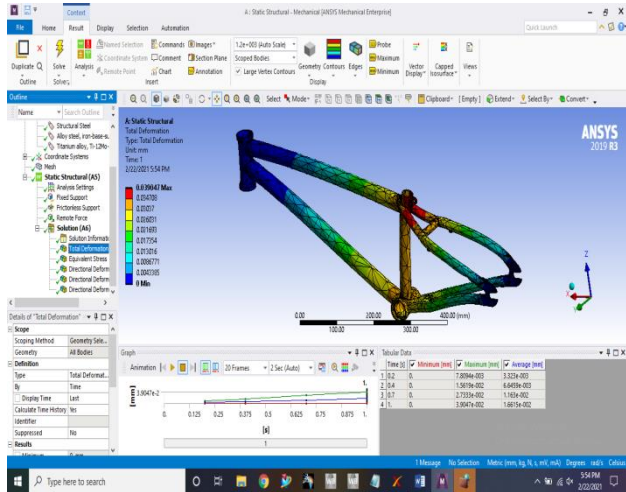

Fig20- Total deformation

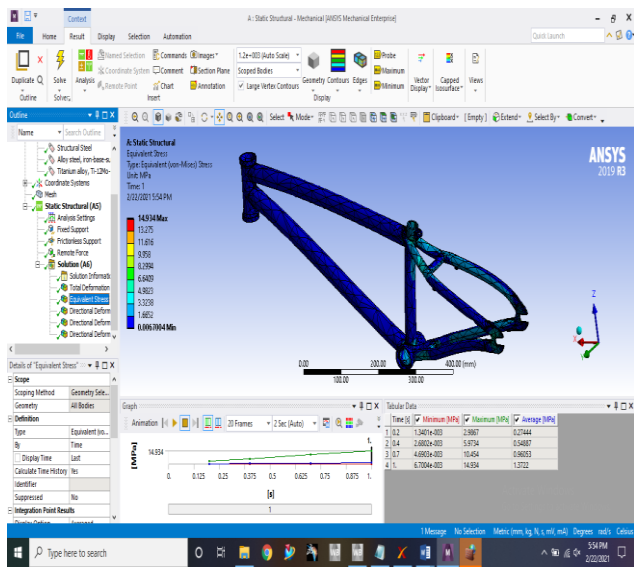

Fig21-Stress

COMPARISON TABLE

SL.NO	MATERIAL S	TOTAL DEFORMATION	Equivalent STRESS
1	STEEL ALLOY	0.01475	15.029
2	ALLOY STEEL SUPER ALLOY A286	0.014689	14.995
3	Ti-12Mo-6Zr-2Fe-titanium alloy	0.039047	14.934

CONCLUSION

In this project we did design of Bicycle Frame by using Catia V5 R20. After completion of design we did structural analysis of bicycle frame with use of Steel alloy, Alloy steel super alloy a286 and Ti-12Mo-6Zr-2Fe-titanium alloy.

After completion of analysis we compared the results of all three materials in that we found that Ti-12Mo-6Zr-2Fe-titanium alloy have lesser deformation and less stress than the other materials .

By this we are concluding that we use Ti-12Mo-6Zr-2Fe-titanium alloy in the place of Steel alloy so that we can increase the life of component.

References

- [1] A. Bonnacorsi, "On the Relationship between Firm Size and Export Intensity," Journal of International Business Studies, XXIII (4), pp. 605-635, 1992. (journal style)
- [2] R. Caves, Multinational Enterprise and Economic Analysis, Cambridge University Press, Cambridge, 1982. (book style)
- [3] M. Clerc, "The Swarm and the Queen: Towards a Deterministic and Adaptive Particle Swarm Optimization," In Proceedings of the IEEE Congress on Evolutionary Computation (CEC), pp. 1951-1957, 1999. (conference style)
- [4] H.H. Crokell, "Specialization and International Competitiveness," in Managing the Multinational Subsidiary, H. Etemad and L. S, Sulude (eds.), Croom-Helm, London, 1986. (book chapter style)
- [5] K. Deb, S. Agrawal, A. Pratab, T. Meyarivan, "A Fast Elitist Non-dominated Sorting Genetic Algorithms for Multiobjective Optimization: NSGA II," KanGAL report 200001, Indian Institute of Technology, Kanpur, India, 2000. (technical report style)
- [6] J. Gerald, "Sega Ends Production of Dreamcast," vnunet.com, para. 2, Jan. 31, 2001. [Online]. Available: <http://nl1.vnunet.com/news/1116995>. [Accessed: Sept. 12, 200